

# HENRY AIRTOOLS

American Made Industrial Tools

## MODELS

56 VL

56 VS



## General Safety and Maintenance Manual



### 3 HORSEPOWER VERTICAL GRINDERS

Model Number	Throttle Type	Power Output	Weight	Height over Spindle	Air Consumption	Rated Speed/Wheel Capacity
56VL	LEVER	3 H.P. (2250 W)	8.8 Lbs. (4.0 Kg)	7.1 Inches 18 cm	45 cfm (21.2 L/s)	4500 RPM w/ 9 Inch T27 Wheel Guard 4500 RPM w/ 9 Inch T28 Wheel Guard 6000 RPM w/ 7 Inch T27 Wheel Guard 6000 RPM w/ 7 Inch T28 Wheel Guard 6000 RPM w/ 9 Inch T27 Wheel Guard 6000 RPM w/ 9 Inch T28 Wheel Guard 8000 RPM w/ 7 Inch T27 Wheel Guard 8000 RPM w/ 7 Inch T28 Wheel Guard (NOTE: Standard RPM is 6000RPM)
56VS	SAFETY LEVER					

**THE HENRY TOOL CO., MANUFACTURED BY HENRY TOOLS**

**498 SO. BELVOIR BLVD., SOUTH EUCLID, OH 44121 U.S.A.**

**PH: (216) 291-1011 OR (800) 826-5257 • FAX: (216) 291-5949 OR (800) 303-2800**

**EMAIL: [DAVIIDH@MSN.COM](mailto:DAVIIDH@MSN.COM) • WEBSITE: [WWW.HENRYTOOLS.COM](http://WWW.HENRYTOOLS.COM)**

**General Operators Instructions and Service Manual**



**MODELS**  
**56 VL**  
**56 VS**

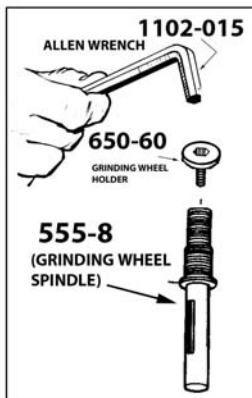
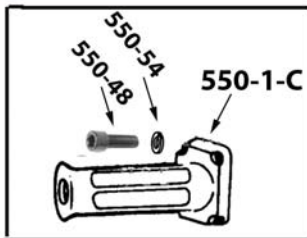
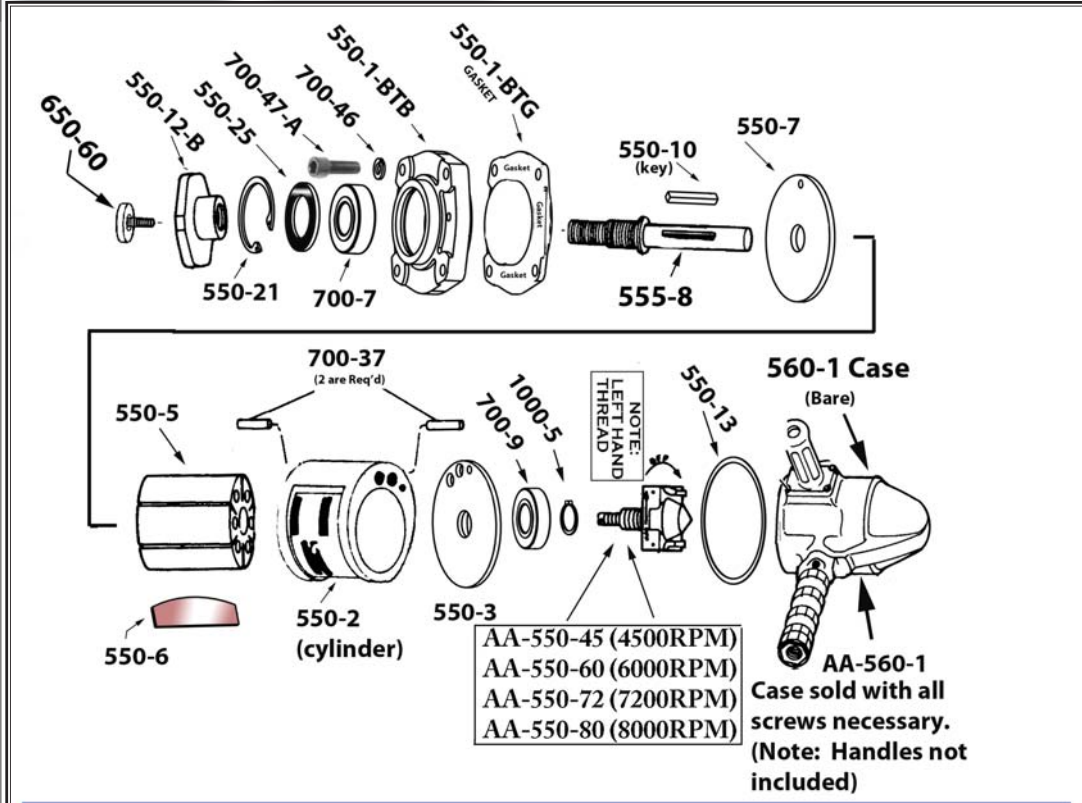

**Guards and Accessories**

700-200 (7" Guard)  
 700-201 (9" Guard)

412988 (6" Cup Guard)

849269 (Depressed Center wheel adaptor kit)

**WRENCHES**

2" WRENCH  
 1100-200

**Spiralcool Pad Setup**

849259

849913 (7" Pad)  
 849914 (9" Pad)

General Operators Instructions and Service Manual



**MODELS**  
**56 VL**  
**56 VS**

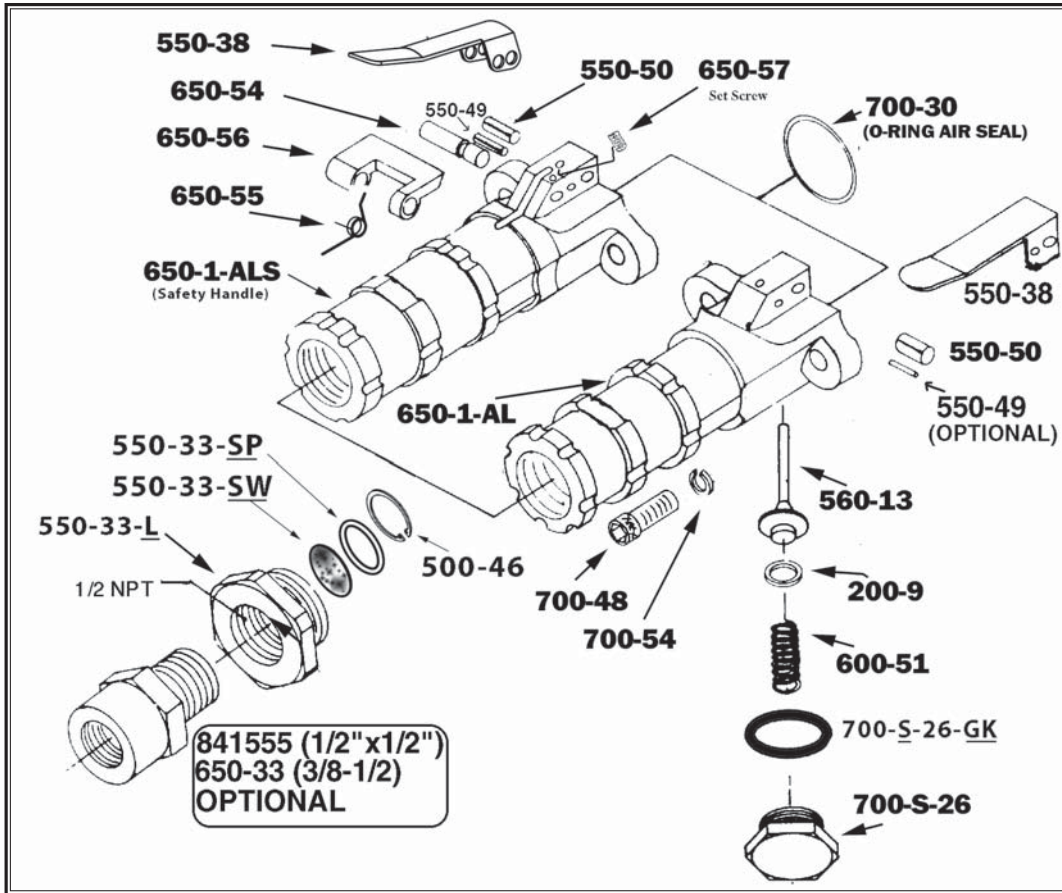

Part No.	Description
200-9	O-Ring
500-46	Snap Ring
550-33-L	Live Handle Adaptor bushing
550-33-SW	Screen Filter
550-33-SP	Spacer
550-38	Lever
550-50	Lever Pin
560-13	Throttle Valve Assembly with 200-9 O-ring installed
600-51	Plunger Spring
650-1-AL	Live Handle Body (Non-Lockout type)
650-1-ALS	Safety Lock Valve Body(Bare)
AA-650-1-AL	Handle Assembly (Complete) (Non-lockout handle)

Part No.	Description
AA-650-1-ALS	Safety Lock Handle Assembly (Complete)
650-33	Screen Bushing(1/2x3/8)
650-54	Safety Lock Pin
650-55	Safety Lock Spring
650-56	Safety Lock Lever
650-57	Set Screw
700-30	O-Ring
700-48	Cap Screw
700-54	Lock Washer
700-S-26	Plug
700-S-26-GK	Gasket
841555	Screen Bushing (1/2X1/2)

HENRY TOOLS, INC. Ph: (216) 291-1011 or (800) 826-5257



**MODELS**  
**56 VL**  
**56 VS**

PART NO.	DESCRIPTION
200-9	O-RING
500-46	SNAP RING
550-1-BT	BEARING SUPPORT(OLD STYLE) still supported by Henrytools
550-1-BTB	BEARING SUPPORT PLATE (NEW STYLE) can be used on ALL 56V Grinders
550-1-BTG	GASKET (4 holed)
550-1-C	DEAD HANDLE
550-2	CYLINDER
550-3	REAR ENDPLATE
550-5	ROTOR
550-6	BLADE (5 REQ.)
550-7	FRONT ENDPLATE
550-8	SPINDLE (See Part #555-8)
550-10	KEY
550-12A	WHEEL FLANGE
550-12B	WHEEL FLANGE
550-13	GASKET
550-21	SNAP RING
550-25	BEARING COVER
550-33L	ADAPTOR CAP
550-33-SW	SCREEN FILTER
550-33-SP	SPACER
550-38	Lever
550-48	SCREW (4 REQ.)
550-49	PIN
550-50	LEVER PIN
550-54	WASHER (4 REQ.)
560-1	Case (Bare)with RPM tag
560-13	VALVE with 200-9 O-RING
555-8	SPINDLE (Updated Version)
650-33	3/8-1/2 BUSHING
650-54	LOCKOUT LEVER PIN
600-51	SPRING
650-55	SPRING
650-56	LOCKOUT LEVER

PART NO.	DESCRIPTION
650-57	SET SCREW
650-58	SCREW
650-60	ASSEMBLY COLLAR AND SCREW
650-1-AL	NON-LOCKOUT LEVER CASE
650-1-ALS	LOCKOUT LEVER CASE BODY
700-6	LOCK RING (OLD STYLE) still supported by Henrytools
700-7	BEARING
700-9	BEARING
700-30	O-RING
700-34	SPINDLE NUT
700-37	CYLINDER PIN
700-46	WASHER (4-8 REQ.)
700-47A	SCREW (4 REQ.)
700-48	SCREW
700-49	SCREW (Old Style)
700-54	WASHER
700-S-26	CAP
700-S-26-GK	GASKET
1000-5	SNAP RING
841555	1/2x1/2 BUSHING
<b>GUARDS</b>	
700-200	7" TYPE 27 GUARD
700-201	9" TYPE 27 GUARD
412988	6" CUP GUARD
<b>WRENCHES</b>	
1100-094	15/16" WRENCH
1100-200	2" WRENCH
1102-015	ALLEN WRENCH
102-SPWR	SANDING PAD NUT WRENCH
<b>REPAIR KITS</b>	
510123	REPAIR KIT (INCLUDES: Bearings, Rotor Blades, Gaskets and Snap Rings).
<b>ASSEMBLIES</b>	
650-50	WHEEL LOCK ASSY.



**MODELS**  
56 VL  
56 VS

PART NO.	DESCRIPTION
AA-560-1	CASE ASSY.(Comes with all screws) Specify the speed
AA-650-1-AL	LEVER LIVE HANDLE ASSEMBLY COMPLETE with screwsNON lockout Style
AA-650-1-ALS	LOCKOUT LEVER LIVE HANDLE AS- SEMBLY COMPLETE with screws
<b>GOVERNORS</b>	
AA-550-45	GOV.ASSY. (4500 RPM)
AA-550-60	GOV.ASSY. (6000 RPM)
AA-550-72	GOV.ASSY.(7200 RPM)
AA-550-80	GOV.ASSY. (8000 RPM)
• OTHER SPEEDS AVAILABLE	
<b>ACCESSORIES</b>	
849259	5/8-11 Sanding Pad Nut
849913	7" SANDING PAD (MAX 8500 RPM)
849914	9" SANDING PAD (MAX 6500RPM)
849269	DEPRESSED CENTER WHL ADAPT KIT
HT-114N	NUT

**849269 WHEEL KIT**

**849269 WHEEL KIT INCLUDES:**  
 (1) Backing Plate  
 (1) HT-114N Nut  
 (1) Wrench

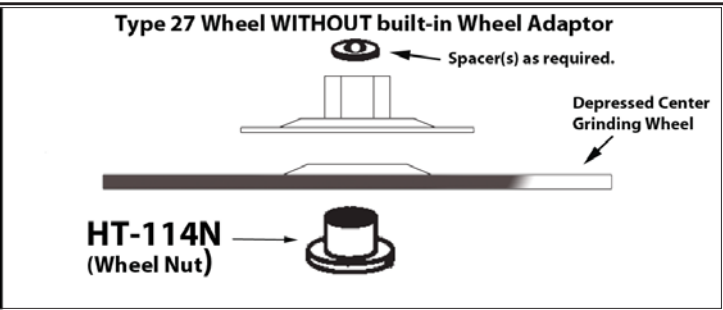
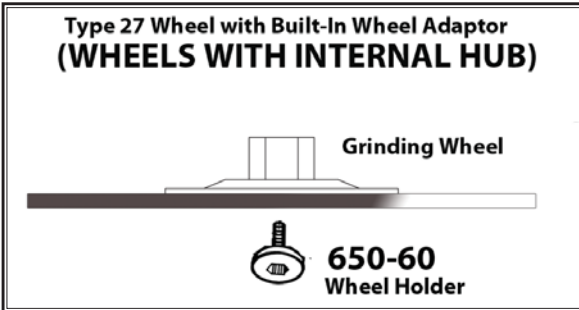

HENRY TOOLS, INC. Ph: (216) 291-1011 or (800) 826-5257

**MODELS**  
**56 VL**  
**56 VS**

**General Wheel Mounting Instructions**

Wheels known to have been subjected to improper mounting procedures can burst violently and should be destroyed rather than risk their use by someone who may not notice that the wheels are damaged.

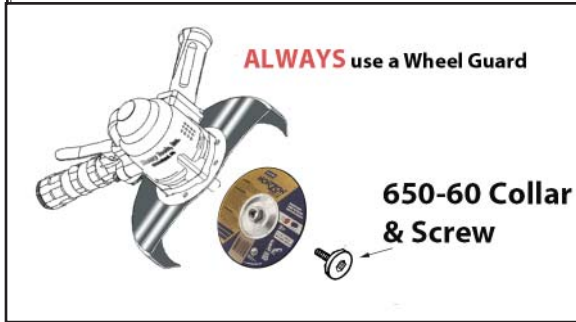

Note: The grinding wheel shown above has threaded hub.

Note: the 650-60 is shipped STANDARD on your Vertical Grinder.

**WARNING: FRAGMENTS FROM AN ABRASIVE WHEEL THAT BREAKS OR COMES APART WHILE ROTATING CAN CAUSE SERIOUS INJURY OR EVEN DEATH. NEVER OPERATE A WHEEL TYPE GRINDER WITHOUT A GUARD.**

**Type 11 Wheel Mounting (CUP WHEELS)**

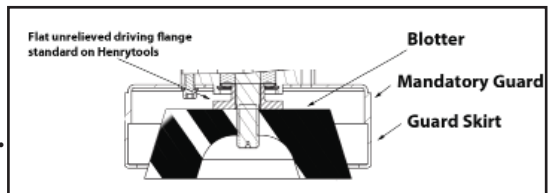

Cup wheels are mounted directly onto the tool. No additional accessories are required.

Type 27, 28 or 29 Depressed center wheels can be mounted as shown below.

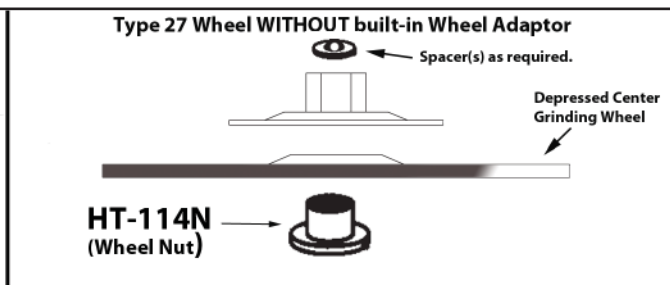
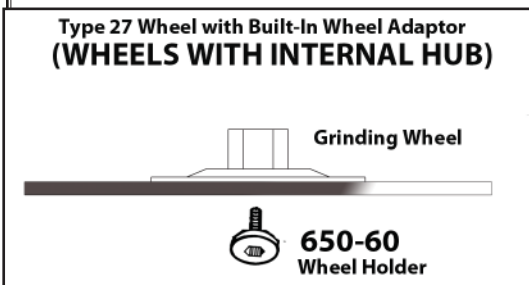

Your new Vertical grinder flanges must be flat, not relieved, and free of nicks or burrs. Flanges for Type 6 or 11 wheels must be at least 1/3 the wheel diameter. Always use wheel retainer supplied by manufacturer on Type 6 or 11 wheels (CupWheels). When using depressed center wheels, only use adapters supplied by the manufacturer unless they are furnished as a part of the wheel. Do not reuse throwaway adapters attached to depressed center wheels by the manufacturer. Spindles must not be bent and threads must be free of any damage that might keep a wheel from being centrally mounted or seated properly against driving flange. Wheel must be sufficiently tightened to prevent spin-off. Before using or after mounting wheel, the tool must be run for one minute in a protected enclosure to check integrity of the wheel.

**INSPECT THE WHEEL OR ACCESSORY**

Check the maximum safe RPM marked on the wheel or accessory. Never use a wheel or accessory rated below the actual tool speed. Cracked, dropped, faulty, or bent accessories are dangerous. Suspect accessories should not be used and should be disposed of. Inspect wheel for cracks or chips, water stains, or signs of abuse or improper storage. Cracked or faulty grinding wheels are dangerous. They must be destroyed rather than risk their use by someone who may not notice that they are damaged.

## General Operators Instructions and Service Manual



## MODELS 56 VL 56 VS

### SAFETY FIRST!

#### ALWAYS COMPLY WITH:

1. General Industry Safety & Health Regulations, Part 1910, OSHA 2206, available from: Sup't of Documents; Government Printing Office; Washington DC 20402
2. Safety Code for Portable Air Tools, ANSI B186.1 available from: American National Standards Institute, Inc.; 1430 Broadway; New York, NY 10018
3. State and Local regulations.

Portions of the above codes and regulations are listed below for quick reference.

THESE EXCERPTS ARE NOT INTENDED TO BE ALL INCLUSIVE - STUDY AND COMPLY WITH ALL REGULATIONS!



## Do Not Throw Away These Instructions!!

#### IMPORTANT SAFETY INFORMATION ENCLOSED.

READ AND UNDERSTAND THIS MANUAL BEFORE OPERATING TOOL. IT IS THE RESPONSIBILITY OF THE EMPLOYER TO PLACE THE INFORMATION IN THIS MANUAL INTO THE HANDS OF THE OPERATOR. FAILURE TO OBSERVE THE FOLLOWING WARNINGS COULD RESULT IN INJURY.

#### PLACING TOOL IN SERVICE

- Always operate, inspect and maintain this tool in accordance with all regulations (local, state, federal and country), that may apply to hand held/hand operated pneumatic tools.
- Always turn off the air supply and disconnect the air supply hose before installing, removing or adjusting any accessory on this tool, or before performing any maintenance on this tool.
- Do not use damaged, frayed or deteriorated air hoses and fittings.
- Be sure all hoses and fittings are the correct size and are tightly secured. Always use clean, dry air at 90 psig (6.2 bar/620 kPa) maximum air pressure. Dust, corrosive fumes and/or excessive moisture can ruin the motor of an air tool.
- Do not lubricate tools with flammable or volatile liquids such as kerosene, diesel or jet fuel.

Do not remove any labels. Replace any damaged label.

1. **TOOL INTENT** - Henry Tools vertical Grinders are designed for heavy material removal. For consistent, quality performance in foundries, welding shops, fabrication facilities, steel mills and shipyards. Tools shall be used only for purposes intended in their design (refer to product catalog).

2. **AIR SUPPLY** - Test and operate tools at 90 PSIG (6.2 bar/620 kPa) maximum air pressure at the inlet with 3/8" (10 mm) inside diameter air supply hose. Use recommended airline filters-regulators-lubricators. Choose tools with enough horsepower to drive the abrasive material you are using, and allow the grinder's speed to work for you.

3. **UNUSUAL SOUND or VIBRATION** - If tool vibrates or produces an unusual sound, repair immediately for correction.

4. **OPERATOR PROTECTIVE EQUIPMENT** - Wear goggles or face shield at all times tool is in operation. Other protective clothing shall be worn, if necessary. SEE REGULATIONS.

5. **SAFETY MAINTENANCE PROGRAM** - Employ a safety program to provide inspection and maintenance of all phases of tool operation and air supply equipment in accordance with "Safety Code for Portable Air Tools."

WARNING: The signal word "Warning" identifies all notes on safe work practices

in this operating instruction, alerting to hazards for life and health of people. Observe these notes and proceed with special care in the cases described. Pass all safety instructions on to other operators. In addition to the safety instructions in this operating instruction, the general local safety and accident prevention rules must be observed.

#### Important Notes

**CAUTION** The signal word "caution!" identifies all portions of this operating instruction meriting special attention to ensure that guidelines, rules, hints and the correct work procedures are observed; and, to prevent damage to and destruction of the grinder and/or parts.

A recommended spare part (or set) for every five (5) tools. Small, low cost or easily lost parts should be stocked as 3-4 per 10 tools.

**WARNING:** Disconnect the air supply hose before servicing the tool.

#### INSTALLATION

For most efficient operation, 90 psig (620 kPa) of clean dry air is required at the tool with the tool running, with-out extreme fluctuation. Minimum recommended hose size is 3/8" I.D. when the length of the hose is eight feet or less. An air line filter and lubricator, should be used. Hose should be blown out before attaching to the tool.

#### Loss of Power

A loss of power may not be related to the tool. First, check the air line pressure. It should be 90 psi at the tool while operating.

#### LUBRICATION

Lubricate the motor with an air line lubricator, using a light air motor oil. Adjust the lubricator to dispense one drop per cycle or three drops per minute.

**CAUTION** Do not use substitutes for oil and grease. This could result in damage to the tool.

#### MAINTENANCE

1. Proper and continuous lubrication.
2. Blow out air hose to assure a clean air supply.
3. Be sure the air filter and line lubricator are clean.
4. Fill the line lubricator before operation.
5. Place a few drops of oil into the air inlet of the tool before attaching the air line.
6. Use moisture separators to remove water from the air line.
7. **CAUTION** Do not use solvent on bearings or on any parts made of a synthetic material.
8. Do not remove bearings unless replacement is necessary; bearings are a press fit.

Always wear eye protection when operating or performing maintenance on this tool.

Always wear hearing protection when operating this tool.

Keep hands, loose clothing and long hair away from rotating end of tool.

Anticipate and be alert for sudden changes in motion during start up and operation of any power tool.

Keep body stance balanced and firm. Do not over-



## MODELS 56 VL 56 VS

reach when operating this tool. High reaction torques can occur at or below the recommended air pressure. Tool accessories may continue to rotate briefly after throttle is released.

Air powered tools can vibrate in use. Vibration, repetitive motions or uncomfortable positions may be harmful to your hands and arms. Stop using any tool if discomfort, tingling feeling or pain occurs.

Seek medical advice before resuming use.

Use accessories recommended by Henry Tools.

This tool is not designed for working in explosive atmospheres.

This tool is not insulated against electric shock.

### Product Description

An Air Grinder is a compressed air powered hand-held rotary power tool driving a rotating arbor (spindle) on which a grinding wheel or other abrasive accessory is mounted. A guard is required on all grinders, unless used with specific abrasive products and under special conditions. See additional warnings given below for Unguarded Grinders.

#### WARNING

##### General Product Safety Information

**• IT IS YOUR RESPONSIBILITY TO MAKE THIS SAFETY INFORMATION AVAILABLE TO OTHERS THAT WILL OPERATE THIS PRODUCT.**

- Failure to observe the following warnings could result in injury.

#### WARNING

Product Safety information - When Placing the Tool in Service

- Always install, operate, inspect and maintain this product in accordance with all applicable standards and regulations (local, state, country, federal, etc.).
- Always use clean, dry air at 90 psig (6.2 bar/620 kPa) maximum air pressure at the inlet. Higher pressure may result in hazardous situations including excessive speed, rupture, or incorrect output torque or force.
- Be sure all hoses and fittings are the correct size and are tightly secured.
- Install a properly sized Safety Air Fuse upstream of hose and use an anti-whip device across any hose coupling without internal shut-off, to prevent hose whipping if a hose fails or coupling disconnects.
- Ensure an accessible emergency shut off valve has been installed in the air supply line, and make others aware of its location.
- Do not use damaged, frayed or deteriorated air hoses and fittings.
- Keep clear of whipping air hoses. Shut off the compressed air before approaching a whipping hose.
- Always turn off the air supply, bleed the air pressure and disconnect the air supply hose before installing, removing or adjusting any accessory on this tool, or before performing any maintenance on this tool or any accessory.
- Do not lubricate tools with flammable or volatile liquids such as kerosene, diesel or jet fuel. Use only recommended lubricants.
- Use only proper cleaning solvents to clean parts. Use only cleaning solvents which meet current safety and health standards. Use cleaning solvents in a well ventilated area.
- Keep work area clean, uncluttered, ventilated and illumi-

nated.

- Do not remove any labels. Replace any damaged label.
- For those grinders designed for use with wheels of four inches diameter and larger, separate the grinder from any quick-disconnect couplings by a hose whip. Never install a quick-disconnect directly into these tools.

#### WARNING

PRODUCT SAFETY INFORMATION - WHEN USING THE TOOL:

- Always wear eye protection when operating or performing maintenance on this tool.

- Always wear hearing protection when operating this tool.

- Always use Personal Protective Equipment appropriate to the tool used and material worked. This may include dust mask or other breathing apparatus, safety glasses, ear plugs, gloves, apron, safety shoes, hard hat and other equipment.

When wearing gloves always be sure that the gloves will not prevent the throttle mechanism from being released.

- Prevent exposure and breathing of harmful dust and particles created by power tool use.

- Some dust created by power sanding, sawing, grinding, drilling, and other construction activities contains chemicals known to cause cancer, birth defects or other reproductive harm. Some examples of these chemicals are:

- lead from lead based paints,
- crystalline silica from bricks and cement and other masonry products, and arsenic and chromium from chemically treated lumber.
- Your risk from these exposures varies, depending on how often you do this type of work. To reduce your exposure to these chemicals: work in a well ventilated area, and work with approved safety equipment, such as those dust masks that are specially designed to filter out microscopic particles.
- Keep others a safe distance from your work area, or ensure they use appropriate Personal Protective Equipment.
- This tool is not designed for working in explosive environments, including those caused by fumes and dust, or near flammable materials.
- This tool is not insulated against electric shock.
- Be aware of buried, hidden or other hazards in your work environment. Do not contact or damage cords, conduits, pipes or hoses that may contain electrical wires, explosive gases or harmful liquids.
- Keep hands, loose clothing, long hair and jewelry away from working end of tool.
- Power tools can vibrate in use. Vibration, repetitive motions or uncomfortable positions may be harmful to your hands and arms. Stop using any tool if discomfort, tingling feeling or pain occurs. Seek medical advice before resuming use.
- Keep body stance balanced and firm. Do not overreach when operating this tool. Anticipate and be alert for sudden changes in motion, reaction torques, or forces during start up and operation.
- Tool and/or accessories may briefly continue their motion after throttle is released.
- To avoid accidental starting - ensure tool is in "off" position before applying air pressure, avoid throttle when carrying, and release throttle with loss of air.
- Ensure work pieces are secure. Use clamps or vises to hold work piece whenever possible.
- Do not carry or drag the tool by the hose.
- Do not use power tools when tired, or under the influence of medication, drugs, or alcohol.
- Never use a damaged or malfunctioning tool or accessory.
- Do not modify the tool, safety devices, or accessories.
- Do not use this tool for purposes other than those recommended.





## MODELS 56 VL 56 VS

### PRODUCT SAFETY INFORMATION - WHEN USING THE TOOL:(CONTINUED)

- Use accessories recommended by Ingersoll-Rand.
  - **Do not use this tool if the actual free speed exceeds the rated rpm.** Check the free speed of the Grinder before mounting a wheel, after all tool repairs, before each job and after every 8 hours of use. Check speed with a calibrated tachometer, without the abrasive product installed.
  - Do not use any wheel or other abrasive accessory whose maximum operating speed, as defined by its manufacturer, is less than the rated speed of the Grinder.
  - Inspect all grinding wheels for chips or cracks prior to mounting. Do not use a wheel that is chipped, cracked or otherwise damaged.
  - Inspect arbor, threads & clamping devices for damage & wear prior to mounting wheel or other abrasive accessory.
  - Do not use a grinding wheel that has been exposed to freezing temperatures, extreme temperature changes, high humidity, solvents, water or other liquids.
  - Make certain grinding wheel or other abrasive accessory properly fits the spindle. The wheel should not fit too snugly or too loosely. Plain hole wheels should have about .007" (0.17 mm) maximum diametral clearance. Do not use reducing bushings to adapt a wheel to any arbor unless such bushings are supplied by and recommended by the wheel manufacturer.
  - Blotters shall always be used between flanges and abrasive wheel surfaces to ensure uniform distribution of flange pressure (except type 27 & 28 wheels) and shall cover the entire contact area of the wheel flange.
  - Always use the wheel flanges furnished by the manufacturer and appropriate for the wheel size and type.
- Never use a makeshift flange or plain washer. Flanges should be in good condition and free of nicks, burrs and sharp edges.
- Ensure that the thread type and size of the threaded abrasive product exactly matches the thread type and size of the spindle.
  - Prevent the spindle end from touching the bottom of the hole of cups, cones or plugs with threaded holes, intended to be mounted on machine spindles, by comparing dimensions and other relevant data for them.
  - Ensure that the grinding wheel or other abrasive accessory is correctly mounted and tightened before use.
  - Before starting this tool, the operator shall make sure that no one is in the plane of rotation.
  - Wear Personal Protective Equipment and remove flammable objects from the work area to ensure that sparks and debris do not create a hazard when using this tool.
  - After mounting a wheel or other abrasive accessory, the Grinder shall be run in a protected enclosure, at gradually increasing speed, for at least 60 seconds. Make certain no one is in front of or in line with the wheel or other abrasive acces-

sory. Be aware that it may fail at this time if it is defective, improperly mounted or the wrong size and speed. Stop immediately if considerable vibration or other defects are detected. Shut off the air supply and determine the cause.

- Do not use this tool on materials whose dust or fumes can cause a potentially explosive environment.
- When starting a cold wheel, apply it to the work slowly until the wheel gradually warms up. Make smooth contact with the work, and avoid any bumping action or excessive pressure.
- If the grinder is dropped or bumped, turn off the air supply and carefully examine the grinding wheel or other abrasive accessory. Discard it if damaged, chipped or cracked. Before reuse, run the grinder in a protected enclosure following the same precautions used after first mounting.
- Before a grinder is put down, the throttle shall be released and the wheel or other accessory shall come to a stop. Tool rests, hangers, and balancers are recommended.

#### Additional Warnings for Guarded Grinders

- Do not use this Grinder without the furnished Wheel Guard.
- Incorrect combinations of grinder wheel, wheel guard and tool speed could result in injury. Ensure that combinations are correct per the Product Specifications.
- Always replace a damaged, bent or severely worn wheel guard. Do not use a wheel guard that has been subjected to wheel failure.
- Guard opening must face away from the operator. Bottom of wheel must not project beyond guard.

#### Additional Warnings for Unguarded Grinders

- Do not use an unguarded grinder unless used for internal work and only operated when the work offers protection.

## NEVER MODIFY ANY PART OF THIS TOOL!!!

Serious injury can result.

HENRY TOOLS, INC. Ph: (216) 291-1011 or (800) 826-5257

**MODELS**  
**56 VL**  
**56 VS**



**PRODUCT SAFETY INFORMATION - WHEN USING THE TOOL:(CONTINUED)**

Additional Warnings for Use of Cut-off Wheels (Type 1 and 27A)

- When cutting, support the workpiece so the slot is kept at constant or increasing width during the whole operation.
- If the abrasive product gets jammed in a cut slot, shut off the grinder and ease the wheel free. Check that the wheel is still correctly secured and not damaged before continuing the operation.
- A cut-off wheel shall not be used for side grinding. The 6 & 11 cup wheels remove large amounts of metal and are good for open spaces. Use a Type 27 & 28 wheel for weld grinding, notch and gate removal, pipe beveling and repair or in metal fabrication, petrochemical maintenance or construction. After mounting a wheel or other abrasive accessory, the Grinder **SHALL** be run in a protected enclosure or under a work bench, at a gradually increasing speed, for at least 60 seconds. Make certain no one is in front of or in line with the wheel or other abrasive accessory. Be aware that it may fail at this time if it is defective, improperly mounted or the wrong size and speed. **STOP IMMEDIATELY** if considerable vibration or other defects are detected. Shut off the air supply and determine the cause.



Your selection and purchase of finishing tools has a direct effect on process and product quality. Your decision can make a difference in finishing efficiency and in the improved quality and durability of finishes. Only use recommended equipment and adaptors. Inspect grinding wheels closely for any imperfections, damage or broken edges. Use correct size guards, flanges, blotters, spindles and mounting practices to ensure operator safety. All give you the ability to match capacity and attachment precisely to the work piece and material for finessing a high quality finish

<b>WARNING</b>	<b>Always wear eye protection when operating or performing maintenance on this tool.</b>

	<b>WARNING</b> Air powered tools can vibrate in use. Vibration, repetitive motions or uncomfortable positions may be harmful to your hands and arms. Stop using any tool if discomfort, tingling feeling or pain occurs. Seek medical advice before resuming use.
--	--



## MODELS 56 VL 56 VS

### DISASSEMBLY

1. Disconnect air and remove all wheels and accessories from grinder.
2. Secure the dead handle (550-1-C) of the grinder in a vice.
3. Remove the four socket head screws (700-47A) and remove wheel guard.
4. Grasp the wheel flange (550-12A) and pull the complete motor assembly from the case. If the case is too tight, put 5/8-11 hex nut on shaft and grip firmly in vise; using soft hammer, remove case assembly by tapping alternately at live and dead handle joints.
5. Put the flats of the wheel flange in the vise and remove governor. (**NOTE: LEFT HAND THREAD**) So removal of the governor should be turned **CLOCKWISE**.
6. Remove lock ring (1000-5). Holding the cylinder (550-2) in the left hand, place a long tap pin in the hole left by the removal of the governor. With a small hammer, tap light]y on the end of this pin, which separates the spindle (555-8) from the rear bearing (700-9) and the rear thrust (550-3). Remove cylinder (550-2), rotor blades (550-6) and rotor (550-5).
7. Do not remove key (550-10) at this time.
8. Clamp spindle holder in vise vertically. Line up the keyway in the holder and slide the spindle assembly through. Remove wheel flange (550-12A) (right hand thread) with suitable wrench.
9. Remove spindle assembly from vice or holder. Remove key and press spindle out of bearing support.(550-1-BTB). Remove snap ring(550-21) and spacer (550-25).
10. To check throttle valve, unscrew plug (700-S-26) and lift out valve spring (600-51) and plunger (560-13). Remove the "o" ring (200-9) with a sharp tool and replace with a new ring.

### REASSEMBLY

1. Seat (700-7) bearing in bearing support(550-1-BTB), then replace spacer (550-25). Replace Snap ring (550-21) into groove.
2. Press spindle into bearing support & through the(700-7) bearing.
3. Place key (550-10) into spindle keyway.
4. Clamp spindle holder in vise vertically. Line up the keyway in the holder and slide the assembly through.
5. Thread wheel flange(550-12-A) clockwise by hand until wheel flange bottoms on bearing. Tighten down with a suitable wrench.
6. Remove assembly from spindle holder.
7. Clamp wheel flange (550-12A) vertically in vise.
8. Line up cylinder pin holes in the bearing support (550-1-BT) and the front thrust (550-7).
9. Put key (550-10) in spindle keyway and slide rotor (550-5) down onto arbor (555-8) and insert blades (550-6). Put cylinder (550-2) into place (**NOTE:**Numerous holes on top of cylinder face upwards toward you).
10. Slip rear bearing (700-9) in rear thrust (550-3) and press

on spindle.(Press on inner race of bearing.) Be sure that short dowel pin in cylinder goes into hole in rear thrust(550-3).

11. Put lock ring (1000-5) on spindle. (Note: There is no groove.)
12. Prior to reassembly inspect governor for gouges, nicks or dents. Screw governor tight in rear spindle.(**NOTE: THIS IS LEFT HAND THREAD**) Oil governor and inside of motor.
13. Assemble live handle; add live and dead handles to case; place gasket (550-13) in rear face of case.
14. Drop motor assembly package in case and line up holes in front bearing support with those in front of case.
15. Line up guard with motor holes. Install the four bolts (700-47A) and lock washers (700-46). Tighten bolts down until snug then back off 1/2 turn.
16. Connect tool to air supply and apply air in several short bursts tightening the motor screws (700-47A) till the tool runs smoothly.

HENRY TOOLS, INC. Ph: (216) 291-1011 or (800) 826-5257